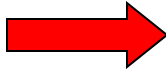

EE 435

Lecture 8:

High-Gain Single-Stage Op Amps

Basic Op Amp Design

- Fundamental Amplifier Design Issues
- Single-Stage Low Gain Op Amps
-  • Single-Stage High Gain Op Amps
- Other Basic Gain Enhancement Approaches
- Two-Stage Op Amp

High output impedance quarter-circuits

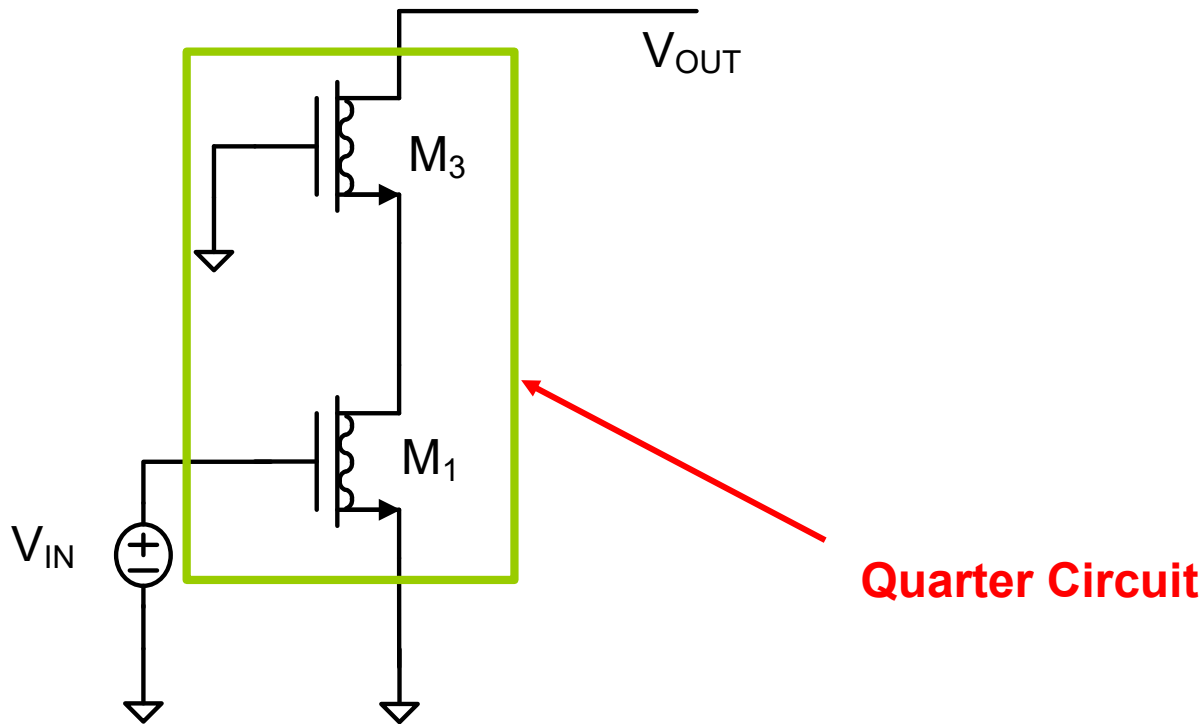

**Cascode Amplifier
(small-signal equiv)**

Telescopic Cascode Op Amp

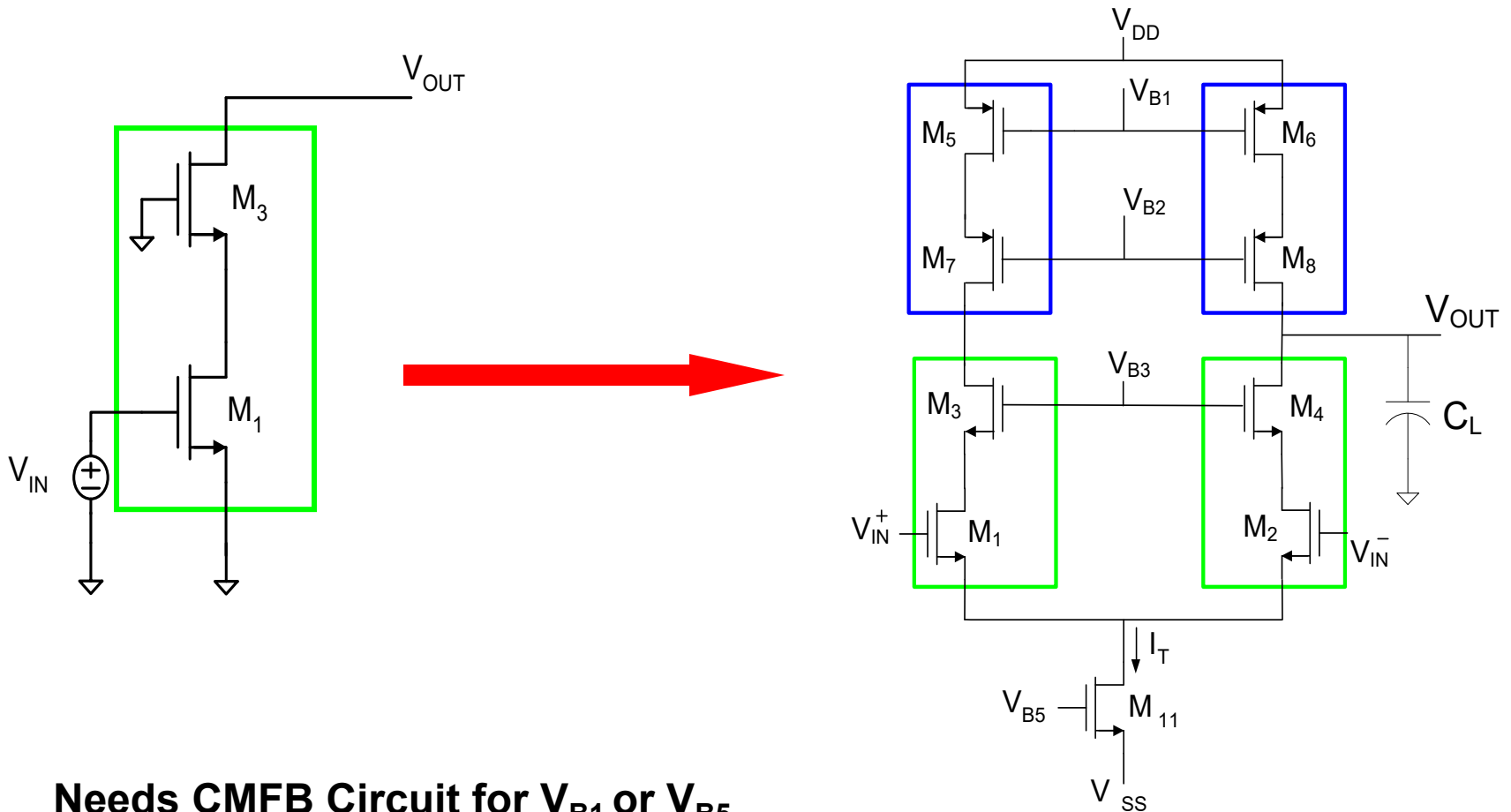

Needs CMFB Circuit for V_{B1} or V_{B5}
Either single-ended or differential outputs
Can connect counterpart as current mirror to eliminate CMFB

Telescopic Cascode Op Amp

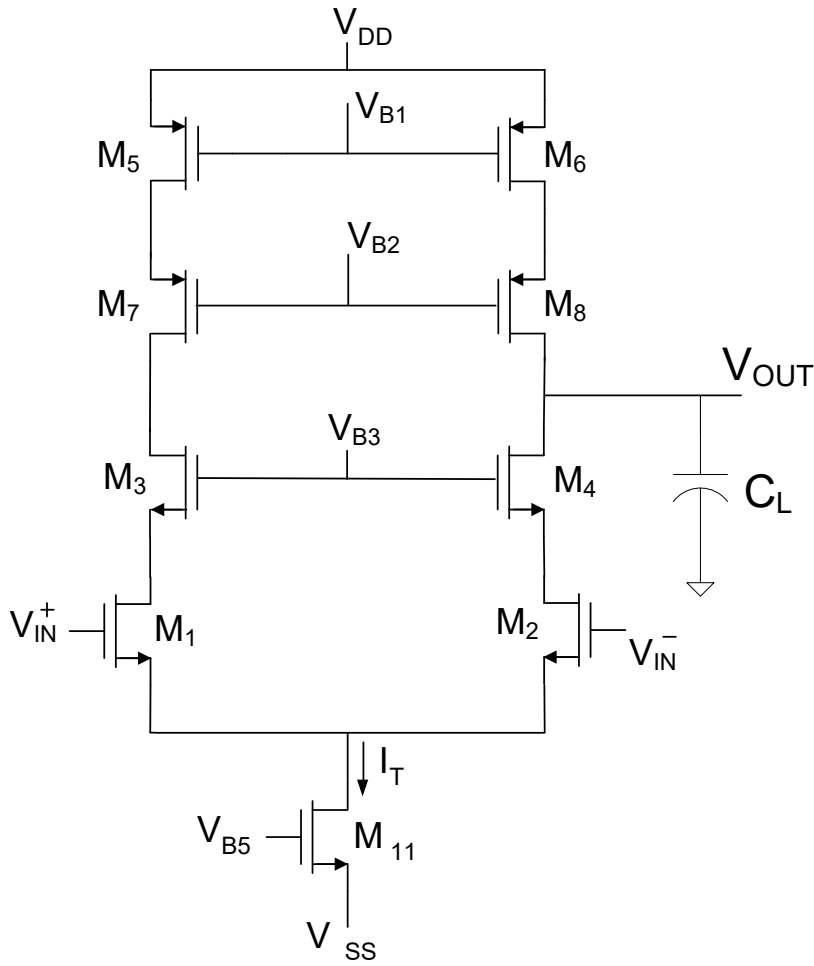

(CMFB circuit not shown)

Single-ended operation

$$A_d(s) = \frac{-\frac{g_{m1}}{2}}{sC_L + g_{o1} \frac{g_{o3}}{g_{m3}} + g_{o5} \frac{g_{o7}}{g_{m7}}}$$

$$A_o = \frac{-\frac{g_{m1}}{2}}{g_{o1} \frac{g_{o3}}{g_{m3}} + g_{o5} \frac{g_{o7}}{g_{m7}}}$$

$$GB = \frac{g_{m1}}{2C_L}$$

- Large improvement in A_o
- No change in GB

This circuit is widely used !!

Telescopic Cascode Op Amp

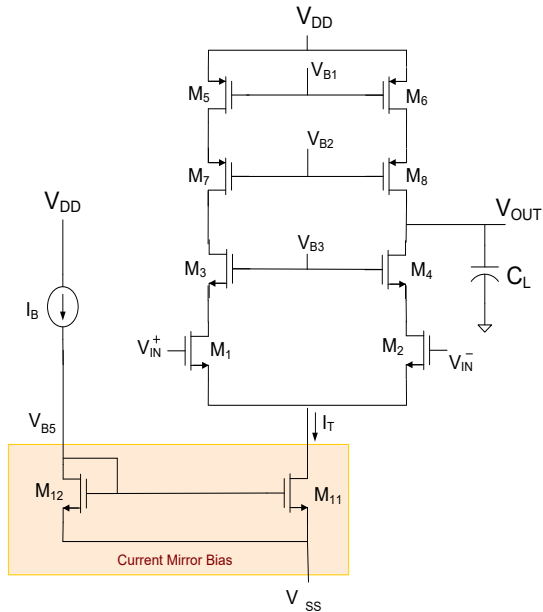

(CMFB circuit needed)

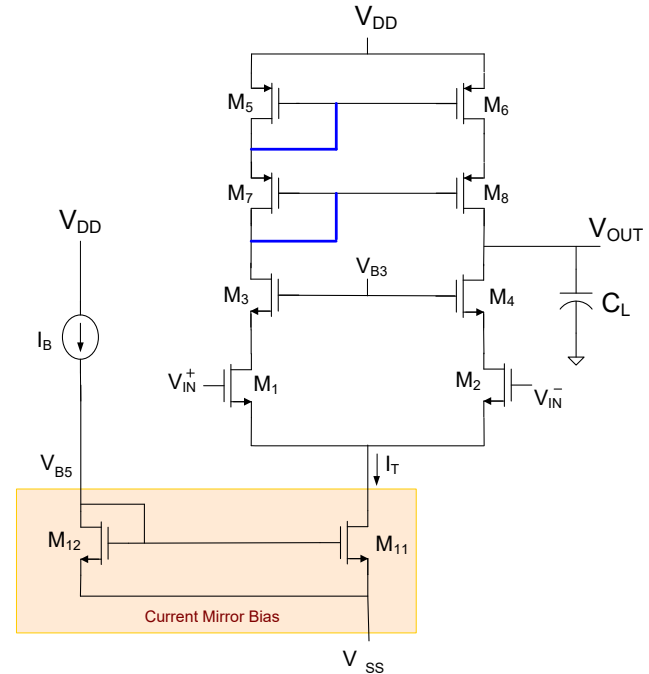

(No CMFB circuit needed)

$$A_d(s) = \frac{-\frac{g_{m1}}{2}}{sC_L + g_{o1} \frac{g_{o3}}{g_{m3}} + g_{o5} \frac{g_{o7}}{g_{m7}}}$$

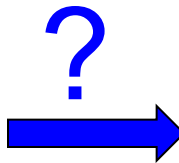

$$A_d(s) = \frac{-g_{m1}}{sC_L + g_{o1} \frac{g_{o3}}{g_{m3}} + g_{o5} \frac{g_{o7}}{g_{m7}}}$$

Review from Last Lecture

Small-Signal model of Telescopic Cascode Amplifier

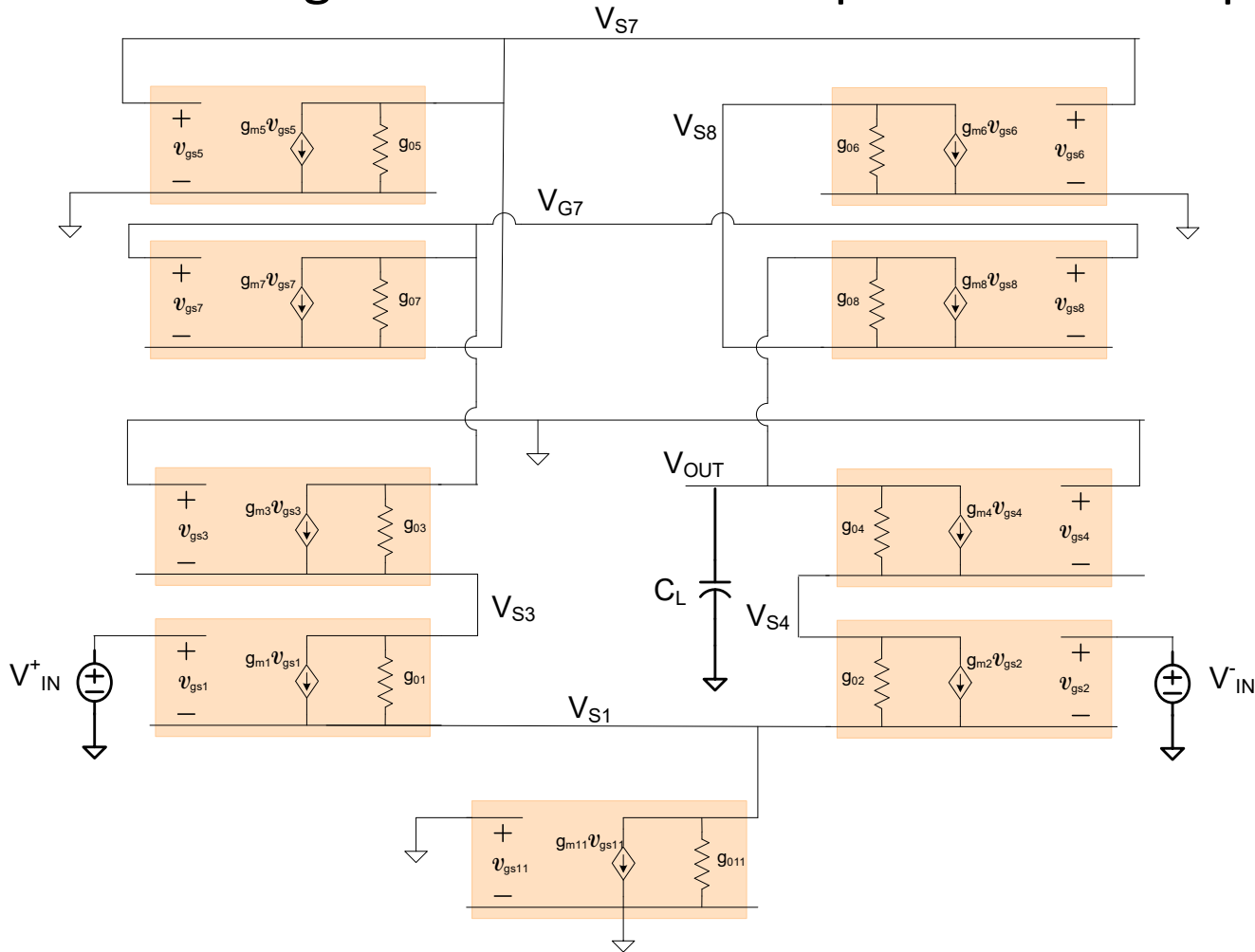

A bit tedious to obtain but really straight forward

Review from Last Lecture

Analysis of Telescopic Cascode Amplifier

Apply KCL at 7 nodes to obtain a set of 7 independent linear equations

$$\left. \begin{aligned} V_{S1}(g_{01} + g_{02} + g_{011}) &= V_{S3}g_{01} + V_{S4}g_{02} + g_{m1}(V_{IN}^+ - V_{S1}) + g_{m2}(V_{IN}^- - V_{S1}) \\ V_{S3}(g_{01} + g_{03}) + g_{m1}(V_{IN}^+ - V_{S1}) &= g_{01}V_{S1} + g_{03}V_{G7} - g_{m3}V_{S3} \\ V_{S4}(g_{02} + g_{04}) + g_{m2}(V_{IN}^- - V_{S1}) &= g_{02}V_{S1} + g_{04}V_{OUT} - g_{m4}V_{S4} \\ V_{OUT}(sC_L + g_{04} + g_{08}) - g_{m4}V_{S4} + g_{m8}(V_{G7} - V_{S8}) &= g_{04}V_{S4} + g_{08}V_{S8} \\ V_{G7}(g_{07} + g_{03}) + g_{m7}(V_{G7} - V_{S7}) - g_{m3}V_{S3} &= g_{03}V_{S3} + g_{07}V_{S7} \\ V_{S8}(g_{06} + g_{08}) + g_{m8}V_{S7} &= g_{m8}(V_{G7} - V_{S8}) + V_{OUT}g_{08} \\ V_{S7}(g_{05} + g_{07}) + g_{m5}V_{S7} &= g_{m7}(V_{G7} - V_{S7}) + g_{07}V_{G7} \end{aligned} \right\}$$

A bit tedious to obtain but really straight forward

Time required to obtain set of equations is quite small

Review from Last Lecture

Individual product terms have product of 7 small-signal parameters

- Approximately 2000 factors in output characteristics
- Approximately 14,000 small-signal parameter appearances
- GB expression much longer

$$\begin{aligned} &V_{inp} * g_{08} * g_{m1} * g_{m2} * g_{m3} * g_{m4} * g_{m5} * g_{m7} + V_{inp} * g_{06} * g_{m1} * g_{m2} * g_{m3} * g_{m4} * g_{m7} * g_{m8} + \\ &V_{inp} * g_{08} * g_{m1} * g_{m2} * g_{m3} * g_{m4} * g_{m7} * g_{m8} + V_{inp} * g_{m1} * g_{m2} * g_{m3} * g_{m4} * g_{m5} * g_{m7} * g_{m8}) \\ &/ \\ &(g_{01} * g_{02} * g_{03} * g_{04} * g_{07} * g_{m8}^2 + g_{01} * g_{02} * g_{03} * g_{04} * g_{m7} * g_{m8}^2 + \\ &g_{01} * g_{02} * g_{04} * g_{07} * g_{m3} * g_{m8}^2 + g_{02} * g_{03} * g_{04} * g_{07} * g_{m1} * g_{m8}^2 + \\ &g_{01} * g_{02} * g_{04} * g_{m3} * g_{m7} * g_{m8}^2 + g_{02} * g_{03} * g_{04} * g_{m1} * g_{m7} * g_{m8}^2 + \end{aligned}$$

$$\begin{aligned} &CL * g_{02} * g_{m3} * g_{m4} * g_{m5} * g_{m7} * g_{m8} * s + CL * g_{03} * g_{m2} * g_{m4} * g_{m5} * g_{m7} * g_{m8} * s + \\ &CL * g_{04} * g_{m2} * g_{m3} * g_{m5} * g_{m7} * g_{m8} * s + CL * g_{05} * g_{m2} * g_{m3} * g_{m4} * g_{m7} * g_{m8} * s + \\ &CL * g_{07} * g_{m2} * g_{m3} * g_{m4} * g_{m5} * g_{m8} * s + CL * g_{08} * g_{m2} * g_{m3} * g_{m4} * g_{m5} * g_{m7} * s + \\ &CL * g_{011} * g_{m3} * g_{m4} * g_{m5} * g_{m7} * g_{m8} * s + CL * g_{m1} * g_{m3} * g_{m4} * g_{m5} * g_{m7} * g_{m8} * s + \\ &CL * g_{m2} * g_{m3} * g_{m4} * g_{m5} * g_{m7} * g_{m8} * s) \end{aligned}$$

Where this started

Telescopic Cascode Op Amp with Mirror-connected Counterpart Circuit

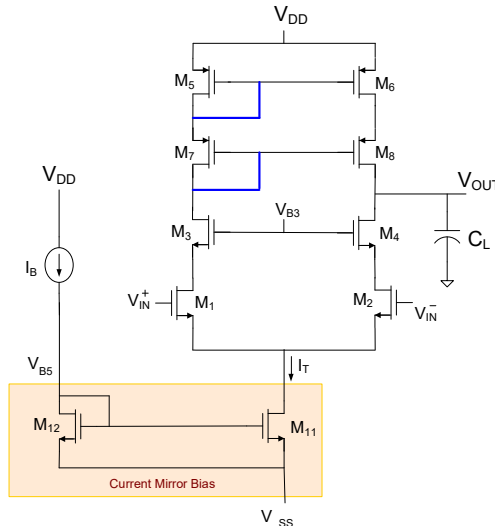

$$A_d(s) = \frac{-g_{m1}}{sC_L + g_{o1} \frac{g_{o3}}{g_{m3}} + g_{o5} \frac{g_{o7}}{g_{m7}}}$$

$$A_d(s) = \frac{-g_{m7}g_{m1}g_{m3}}{sC_L g_{m7}g_{m3} + g_{m7}g_{o3}g_{o1} + g_{m3}g_{o5}g_{o7}}$$

- Some assumptions were made to simplify analysis
 - $V_{ac}=0$ at “approximate axis of symmetry”
 - Matched left and right side transistors
 - Current mirror used to mirror left-side current to right side
- Difference Mode Gain has only approximately 1100 product terms
- Difference Mode Gain has approximately 7700 small-signal parameters in expression

How many product terms are present in the simplified analysis?

How many small-signal parameters are in simplified expression?

- Simplified Difference Mode Gain has 4 product terms
- Simplified Difference Mode Gain has 12 small-signal parameters in expression

Are there other high output impedance circuits that can be used as quarter circuits?

$$A_{VO} = \frac{-G_{M1}}{2(G_1 + G_2)}$$

$$BW = \frac{G_1 + G_2}{C_L}$$

$$GB = \frac{G_{M1}}{2C_L}$$



Are there other high output impedance circuits that can be used as quarter circuits ?

Regulated cascode circuits have the high output impedance property



High output impedance quarter-circuits

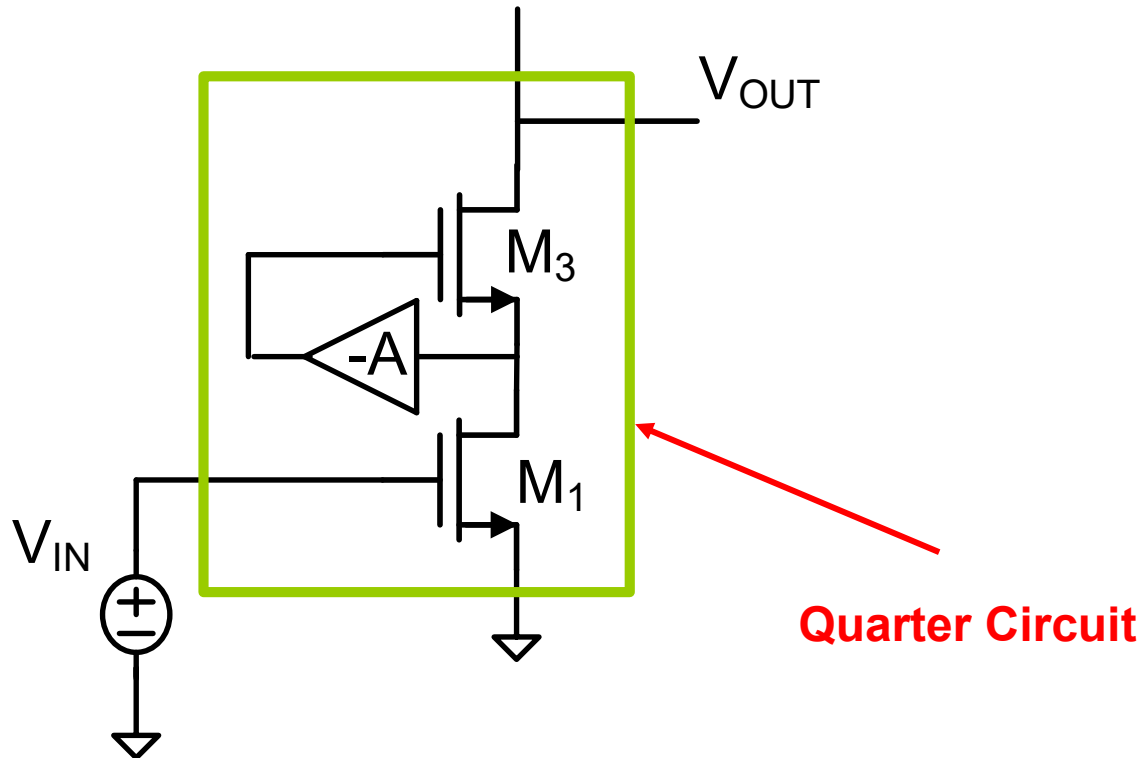

**Regulated Cascode Amplifier
or “Gain Boosted Cascode”**

- A is usually a simple amplifier, often the reference op amp with + terminal connected to the desired quiescent voltage
- Assume biased with a dc current source (not shown) at drain of M_3

Background

Analysis of Regulated Cascode Amplifier

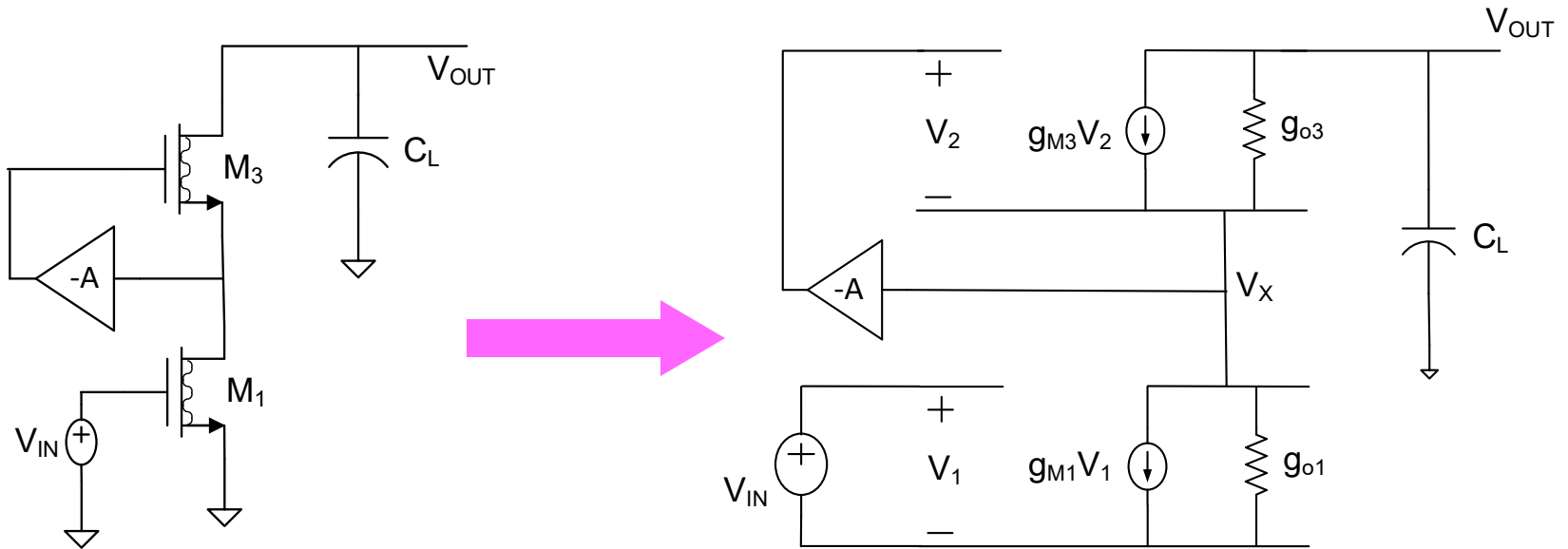

$$\left. \begin{aligned} V_{OUT}(g_{o3} + sC_L) + g_{m3}V_2 &= V_X g_{o3} \\ V_X(g_{o1} + g_{o3}) + g_{m1}V_{IN} - g_{m3}V_2 &= V_{OUT}g_{o3} \\ V_2 + V_X &= -AV_X \end{aligned} \right\}$$

V_X and V_2 can be easily eliminated from these 3 equations

Background

Analysis of Regulated Cascode Amplifier

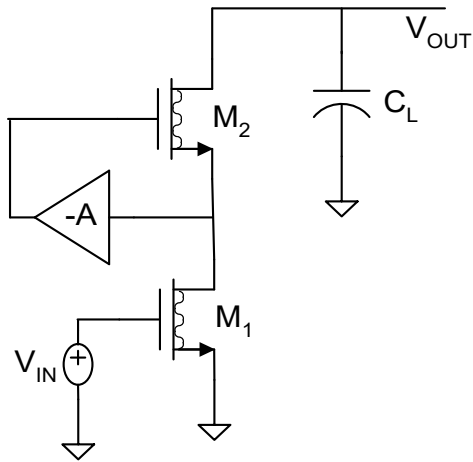

$$\left. \begin{aligned} V_{OUT} (g_{o3} + sC_L) + g_{m3} V_2 &= V_X g_{o3} \\ V_X (g_{o1} + g_{o3}) + g_{m1} V_{IN} - g_{m3} V_2 &= V_{OUT} g_{o3} \\ V_2 + V_X &= -A V_X \end{aligned} \right\}$$

$$\left. \begin{aligned} V_{OUT} (g_{o3} + sC_L) - g_{m3} V_X (1 + A) &= V_X g_{o3} \\ V_X (g_{o1} + g_{o3}) + g_{m1} V_{IN} + g_{m3} V_X (1 + A) &= V_{OUT} g_{o3} \end{aligned} \right\}$$

$$\frac{V_{OUT}}{V_{IN}} = \frac{-g_{m1} (g_{o3} + g_{m3} [1 + A])}{sC_L (g_{o1} + g_{o3} + g_{m3} [1 + A]) + g_{o1} g_{o3}} \approx \frac{-g_{m1} g_{m3} [1 + A]}{sC_L g_{m3} [1 + A] + g_{o1} g_{o3}} = \frac{-g_{m1}}{sC_L + \frac{g_{o1} g_{o3}}{g_{m3} [1 + A]}}$$

for A large:

$$\frac{V_{OUT}}{V_{IN}} \approx \frac{-g_{m1}}{sC_L + g_{o1} \left(\frac{g_{o3}}{g_{m3}} \right) \left(\frac{1}{A} \right)}$$

g_{MEQ}
 g_{OEQ}

High output impedance quarter-circuits

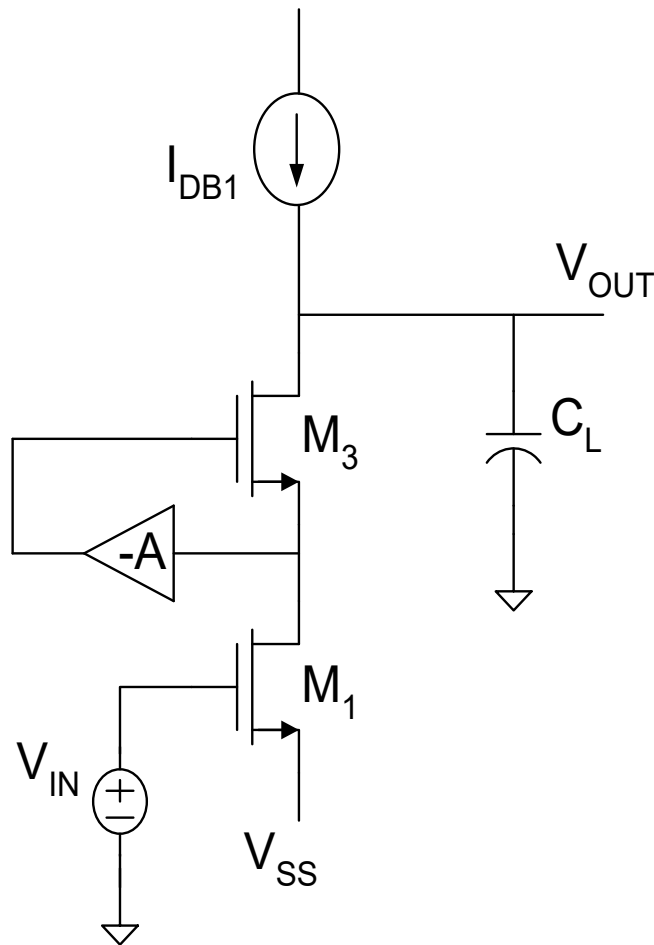

**Regulated Cascode Amplifier
or “Gain Boosted Cascode”**

$$g_{OEQ} \cong g_{o1} \left[\frac{g_{o3}}{g_{m3}} \frac{1}{A} \right]$$

$$g_{mEQ} \cong g_{m1}$$

Based upon small-signal analysis it appears that the output conductance has been decreased even more!

$$A_V \cong \frac{-g_{m1}}{sC_L + g_{o1} \left(\frac{g_{o3}}{g_{m3}A} \right)}$$

$$A_O \cong -\frac{g_{m1}}{g_{o1}} \bullet \left[\frac{g_{m3}A}{g_{o3}} \right]$$

$$GB \cong \frac{g_{m1}}{C_L}$$

Same GB as for previous two circuits

Must verify improvement in gain in practical parameter domain !!

Verification will show predicted improvements

Gain-Boosted Telescopic Cascode Op Amp

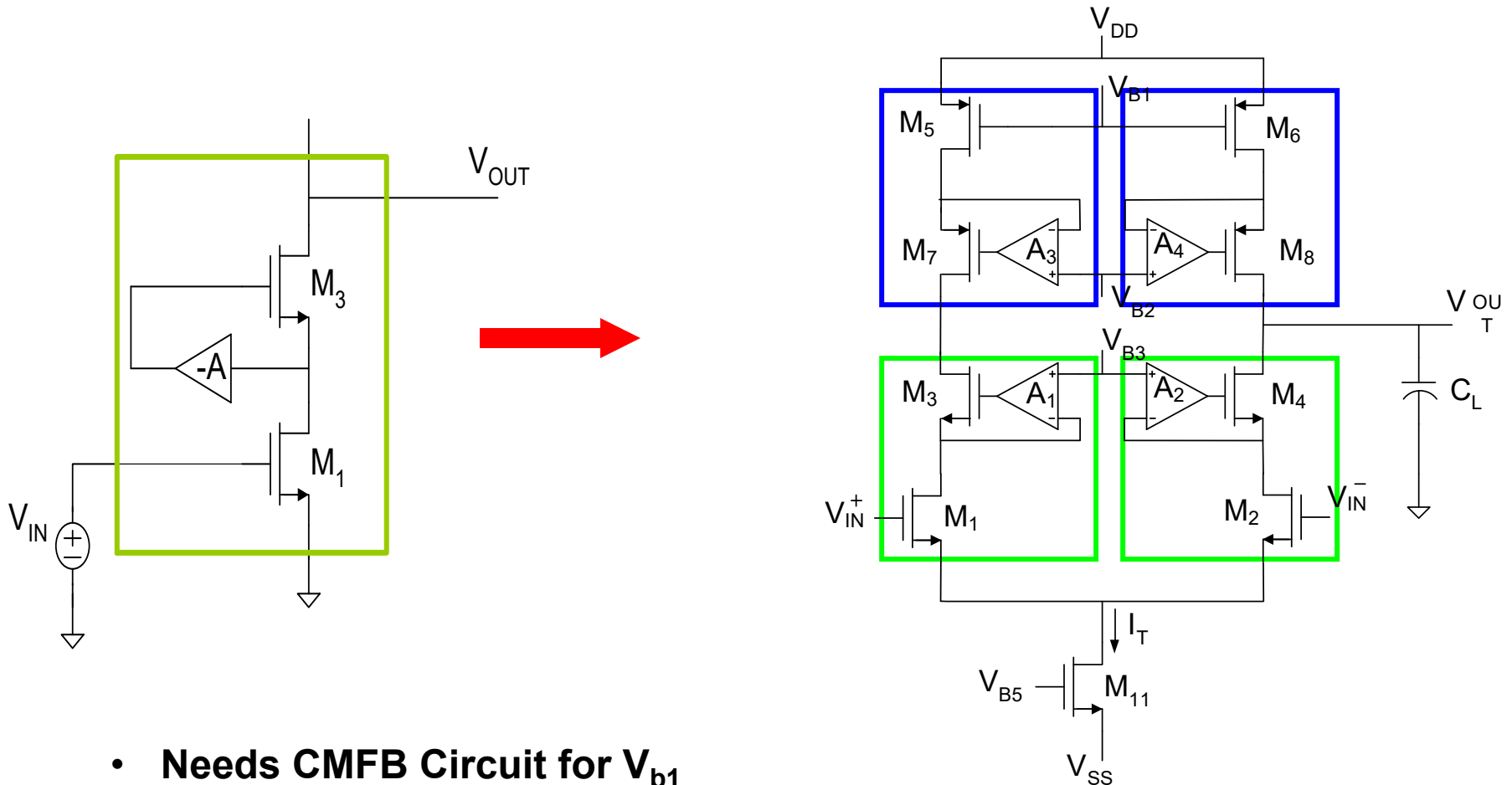

- Needs CMFB Circuit for V_{b1}
- Either single-ended or differential outputs
- Can connect counterpart as current mirror to eliminate CMFB
- Use differential op amp to facilitate biasing of cascode device

Recall from earlier lecture:

-- The “differential” gain --

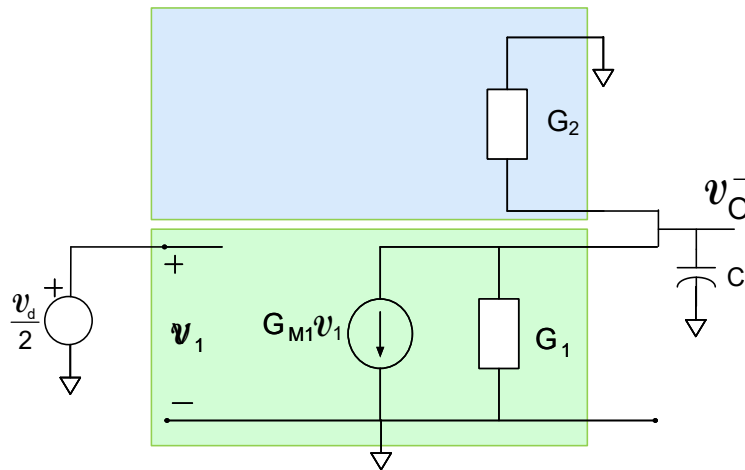

$$A_{Vd} = \frac{v_o^-}{v_d} = \frac{-\frac{G_{M1}}{2}}{sC_L + G_1 + G_2}$$

Gain-Boosted Telescopic Cascode Op Amp

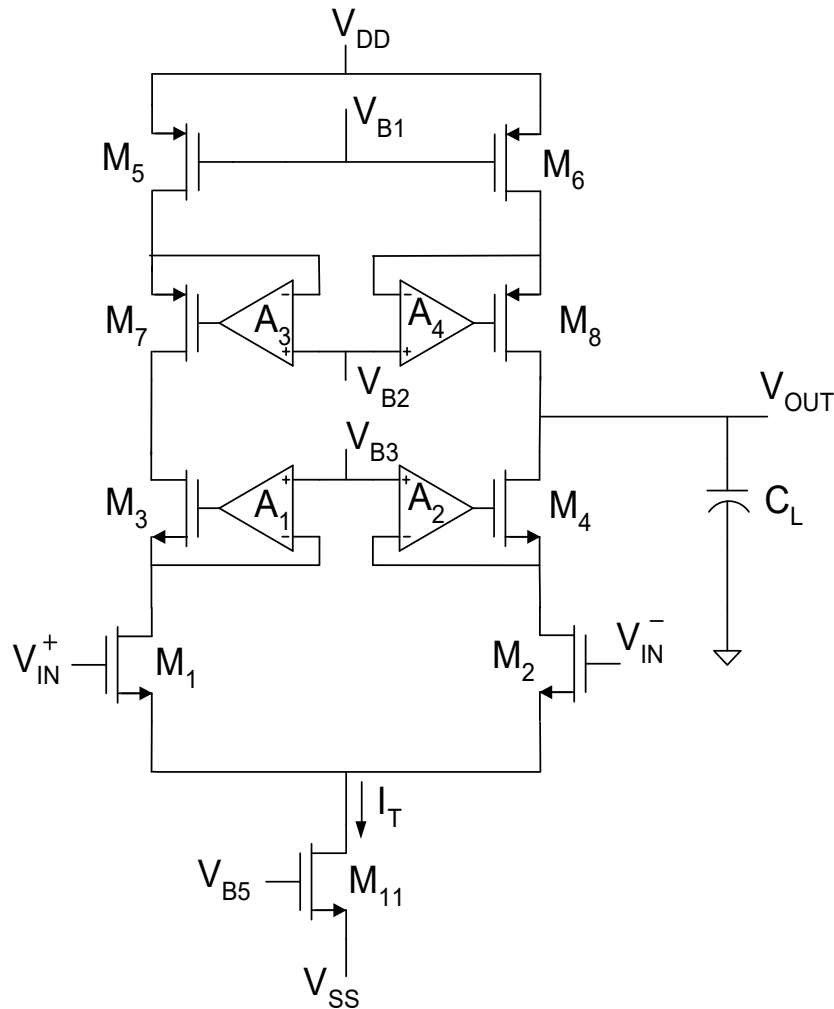

Single-ended operation

$$g_{oQC} = \underline{\hspace{10em}}$$

$$g_{oCC} = \underline{\hspace{10em}}$$

$$g_{mQC} = \underline{\hspace{10em}}$$

Gain-Boosted Telescopic Cascode Op Amp

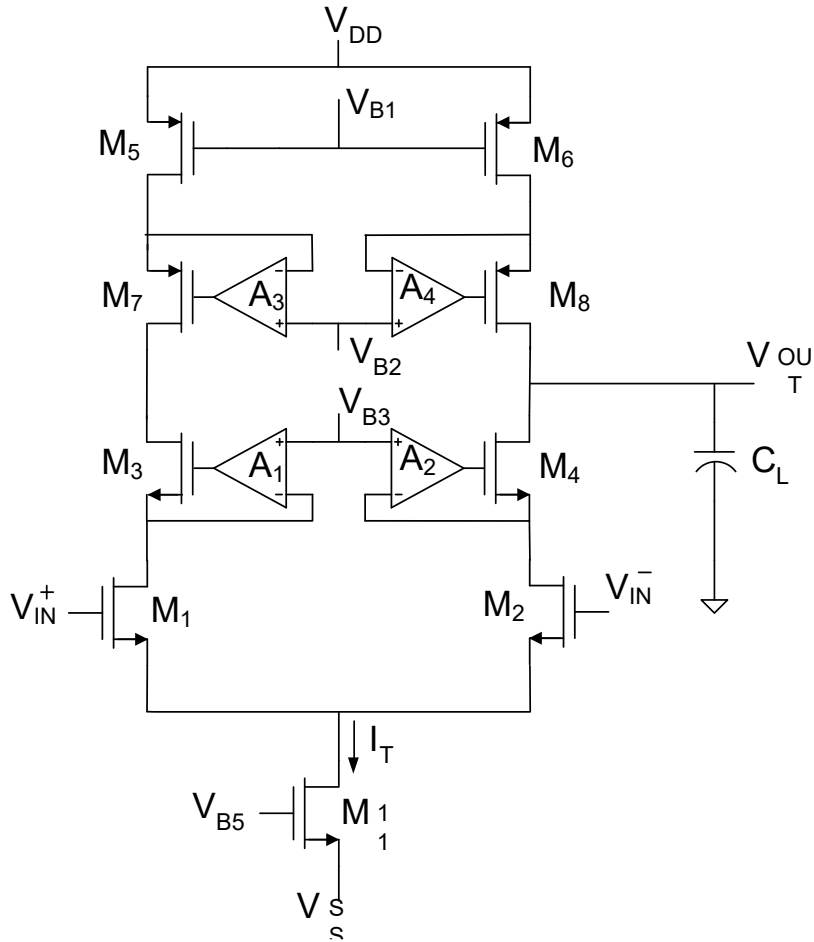

$$A(s) = \frac{-\frac{g_{m1}}{2}}{sC_L + g_{o1} \frac{g_{o3}}{A_1 g_{m3}} + g_{o5} \frac{g_{o7}}{A_3 g_{m7}}}$$

Gain-Boosted Telescopic Cascode Op Amp

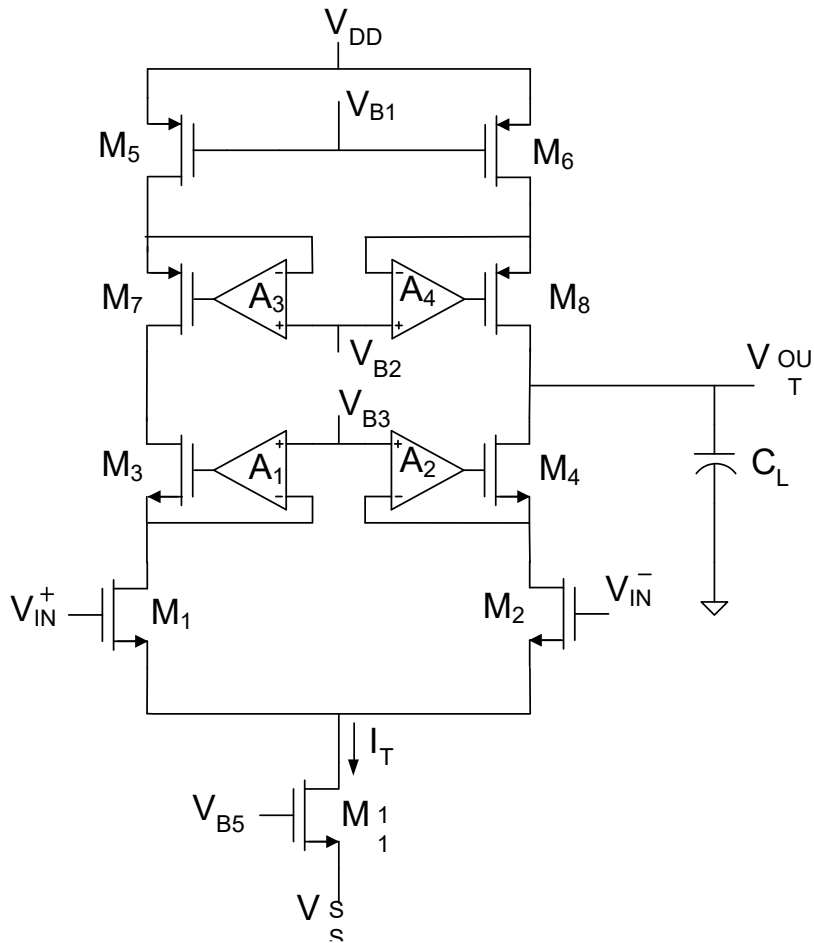

$$A_o = \frac{-\frac{g_{m1}}{2}}{g_{o1} \frac{g_{o3}}{A_1 g_{m3}} + g_{o5} \frac{g_{o7}}{A_3 g_{m7}}}$$

$$BW = \frac{g_{o1} \frac{g_{o3}}{A_1 g_{m3}} + g_{o5} \frac{g_{o7}}{A_3 g_{m7}}}{C_L}$$

$$GB \cong \frac{g_{m1}}{2C_L}$$

This is modestly less efficient at generating GB because now power is consumed in both the cascode devices and the boosting amplifier

Gain-Boosted Telescopic Cascode Op Amp

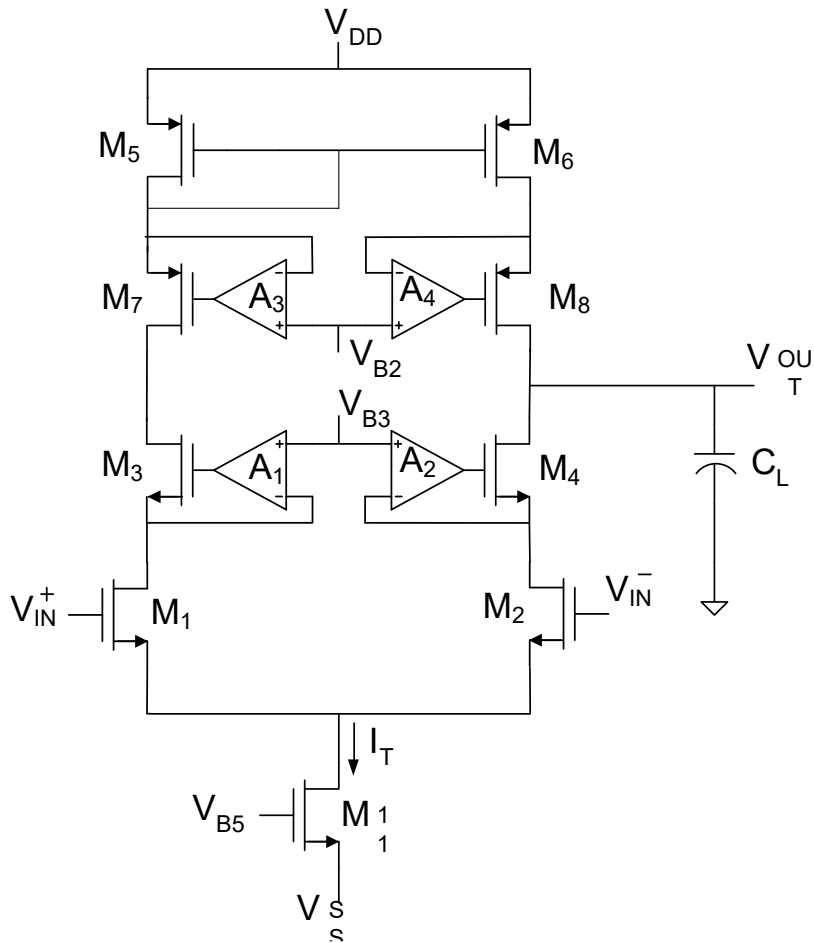

$$A_o = \frac{-g_{m1}}{g_{o1} \frac{g_{o3}}{A_1 g_{m3}} + g_{o5} \frac{g_{o7}}{A_3 g_{m7}}}$$

$$GB = \frac{g_{m1}}{C_L}$$

This is modestly less efficient at generating GB because now power is consumed in both the cascode devices and the boosting amplifier

Elimination of need for CMFB Circuit

Gain-Boosted Telescopic Cascode Op Amp

Signal Swing and Power Supply Limitations

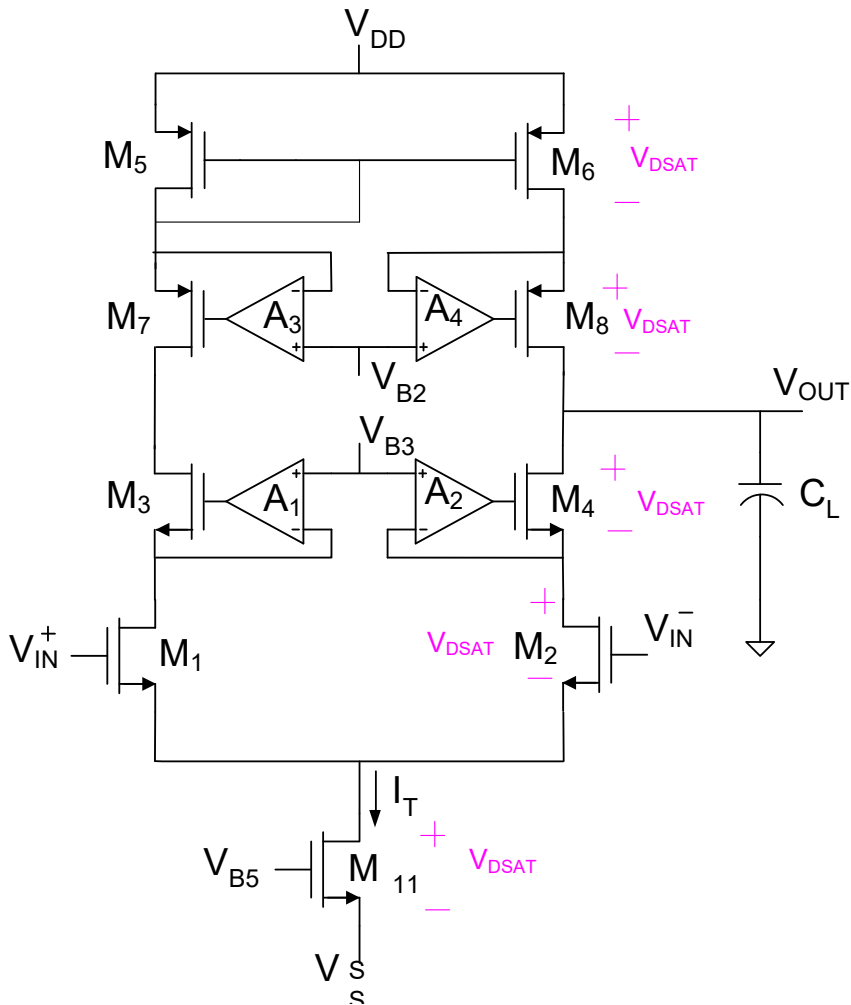

A minimum of 5 V_{DSAT} drops between V_{DD} and V_{SS}

This establishes a lower bound on $V_{DD}-V_{SS}$ and it will be reduced by the p-p signal swing on the output

Gain-Boosted Telescopic Cascode Op Amp

(with or w/o current mirror counterpart circuits)

Advantages:

Significant increase in dc gain

Limitations:

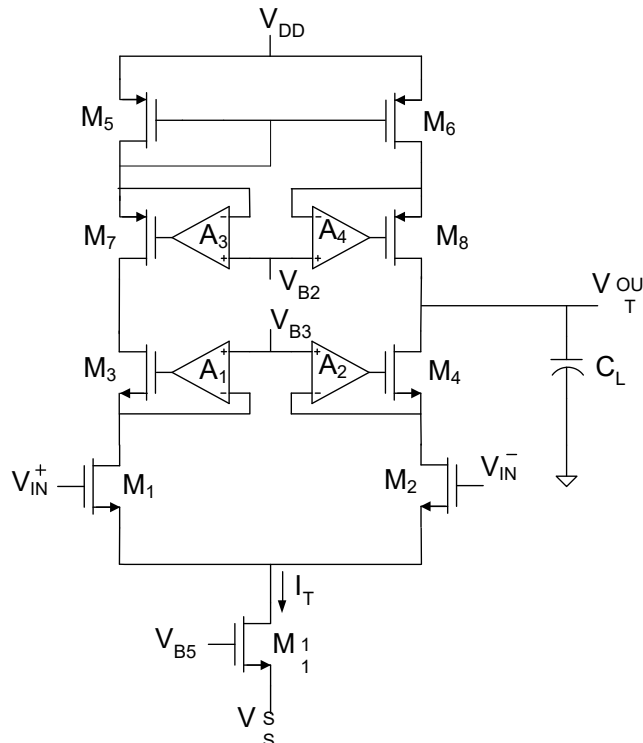

- Signal swing ($4V_{DSAT} + V_T$ between V_{DD} and V_{SS})
- Reduction in GB power efficiency
 - some current required to bias “A” amplifiers
- -additional pole in “A” amplifier
 - may add requirements for some compensation
- Area Overhead for 4 transistors and 4 amplifiers
 - actually minor concern since performance will usually justify these resources

Where we are at:

Basic Op Amp Design

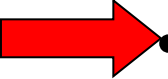
- Fundamental Amplifier Design Issues
- Single-Stage Low Gain Op Amps
-  • Single-Stage High Gain Op Amps
- Other Basic Gain Enhancement Approaches
- Two-Stage Op Amp

Are there other useful high output impedance circuits that can be used for the quarter circuit?

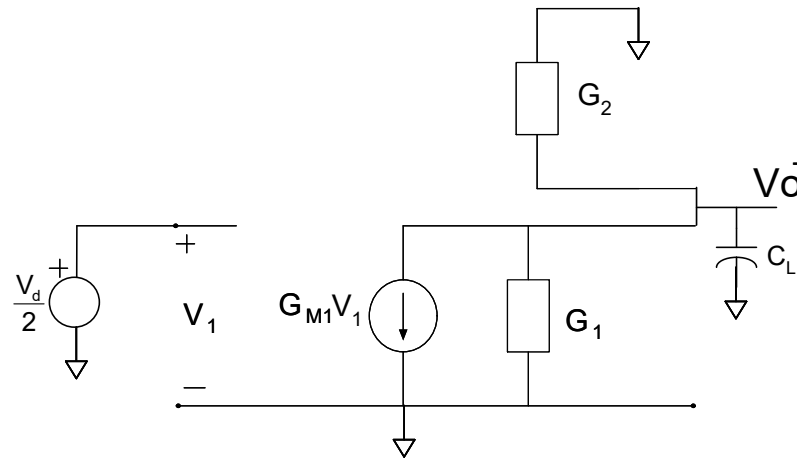

$$A_{V0} = \frac{-G_{M1}}{2(G_1 + G_2)}$$

$$BW = \frac{G_1 + G_2}{C_L}$$

$$GB = \frac{G_{M1}}{2C_L}$$

What circuit is this?

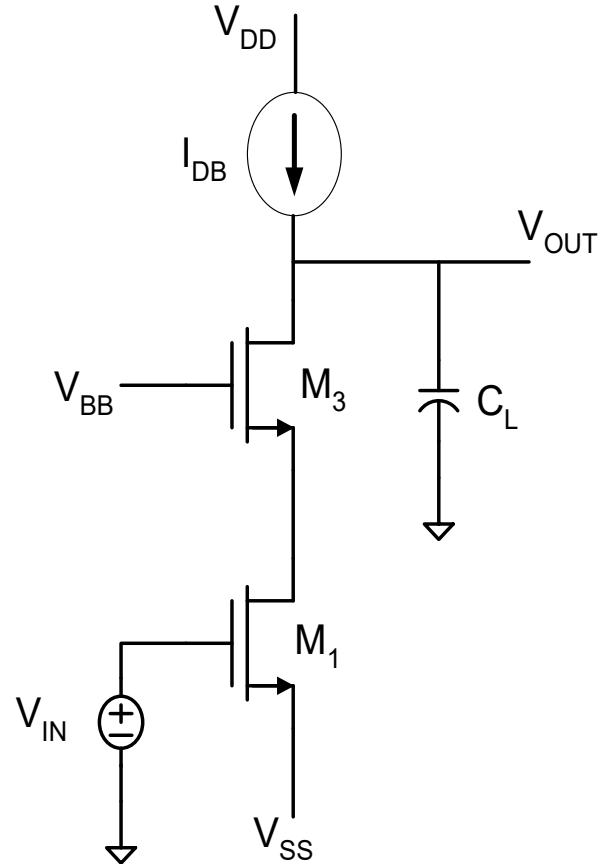
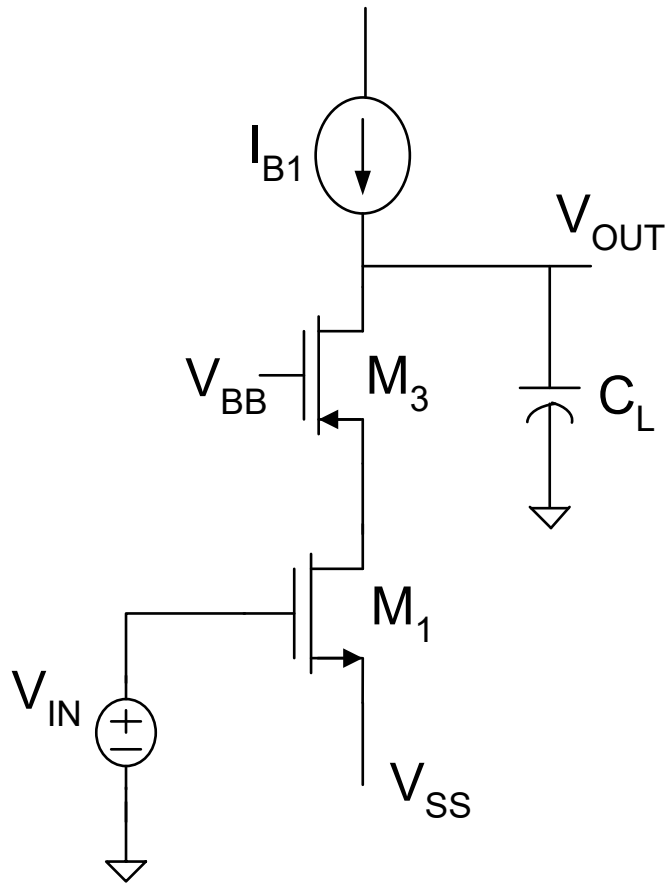

Cascode Amplifier

What circuit is this?

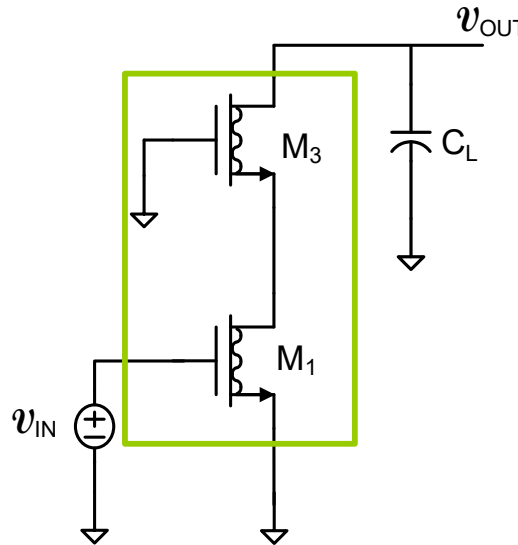
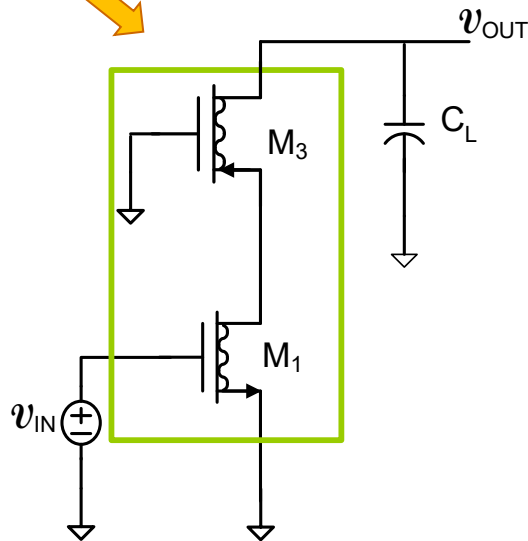
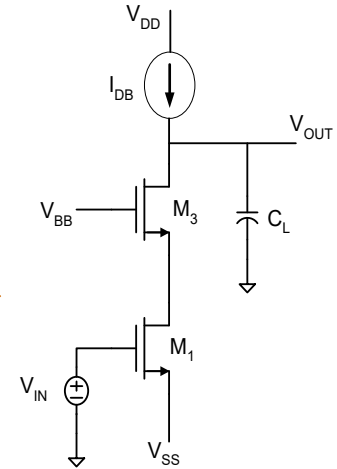
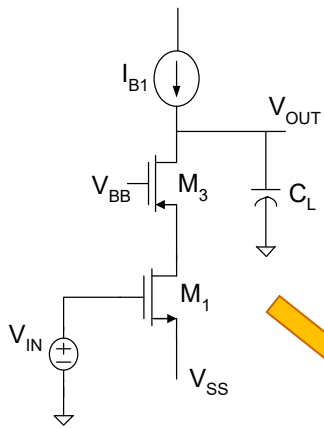

Small-signal circuit structures are identical !

• Cascode Amplifier

- Often termed a “Folded Cascode Amplifier”
- Same small-signal performance as other
- V_{OUT} swing $V_{DSAT1} - V_{DSAT2}$ could be small or negative
- **But a biasing problem !!**

Cascode Amplifier

Biased Folded Cascode Amplifier

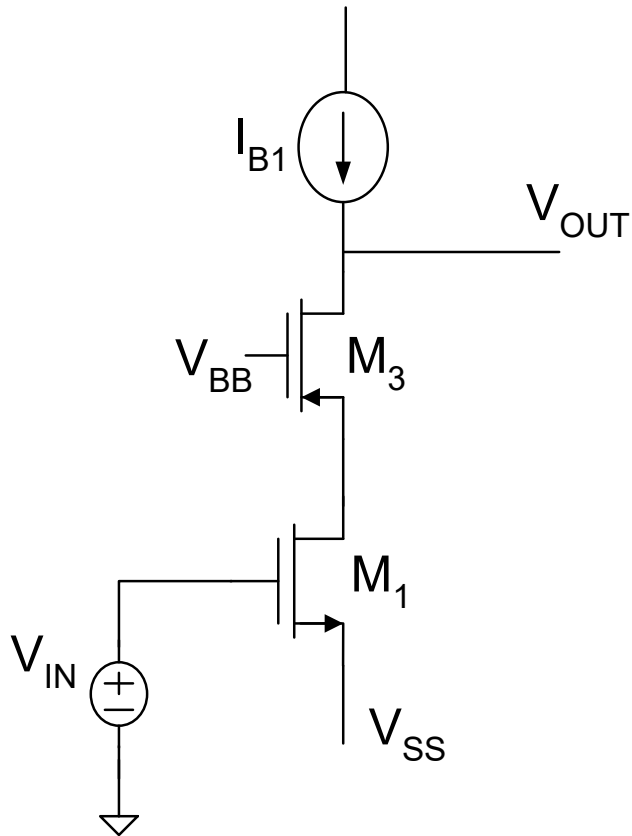

Folded Cascode Amplifier

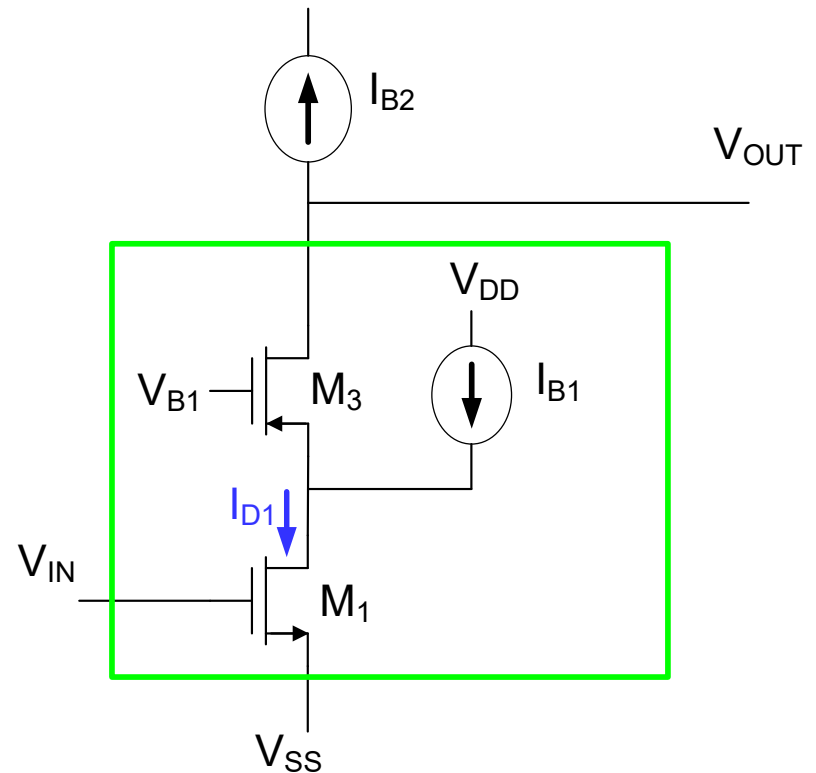

Biased Folded Cascode

Must have $I_{D1} = I_{B1} - I_{B2} > 0$

Implementation of Biased Folded Cascode Amplifier?

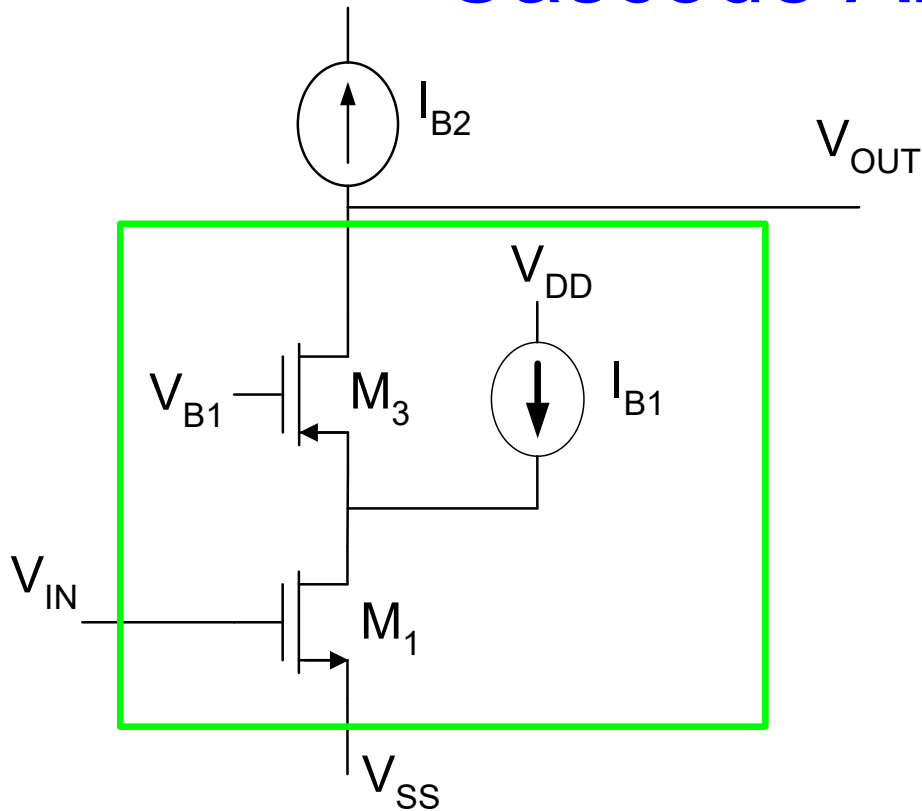

Biased Folded Cascode

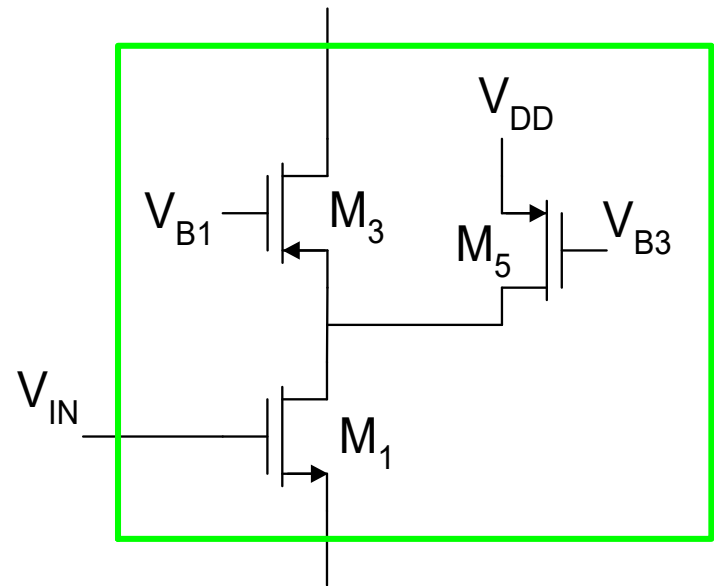

Implementation of Biased Folded Cascode

Analysis of Biased Folded Cascode

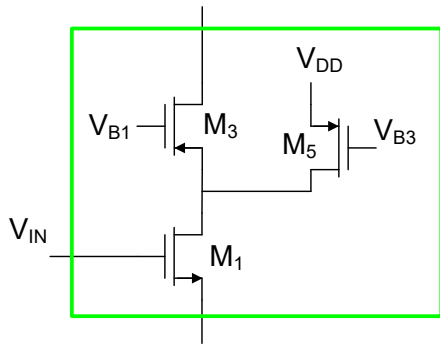

$$\left. \begin{aligned} V_{OUT} (g_{o3} + sC_L) + g_{m3} V_3 &= V_X g_{o3} \\ V_X (g_{o1} + g_{o3} + g_{o5}) + g_{m1} V_1 - g_{m3} V_3 &= V_{OUT} g_{o3} \\ V_3 &= -V_X \\ V_1 &= V_{IN} \end{aligned} \right\}$$

$$\left. \begin{aligned} V_{OUT} (g_{o3} + sC_L) + (g_{m3} + g_{o3}) V_3 &= 0 \\ +g_{m1} V_{IN} = V_3 (g_{m3} + g_{o1} + g_{o3} + g_{o5}) + V_{OUT} g_{o3} \end{aligned} \right\}$$

$$\frac{V_{OUT}}{V_{IN}} \cong - \frac{g_{m1}}{sC_L + (g_{o1} + g_{o5}) \frac{g_{o3}}{g_{m3}}} G_M$$

G_O

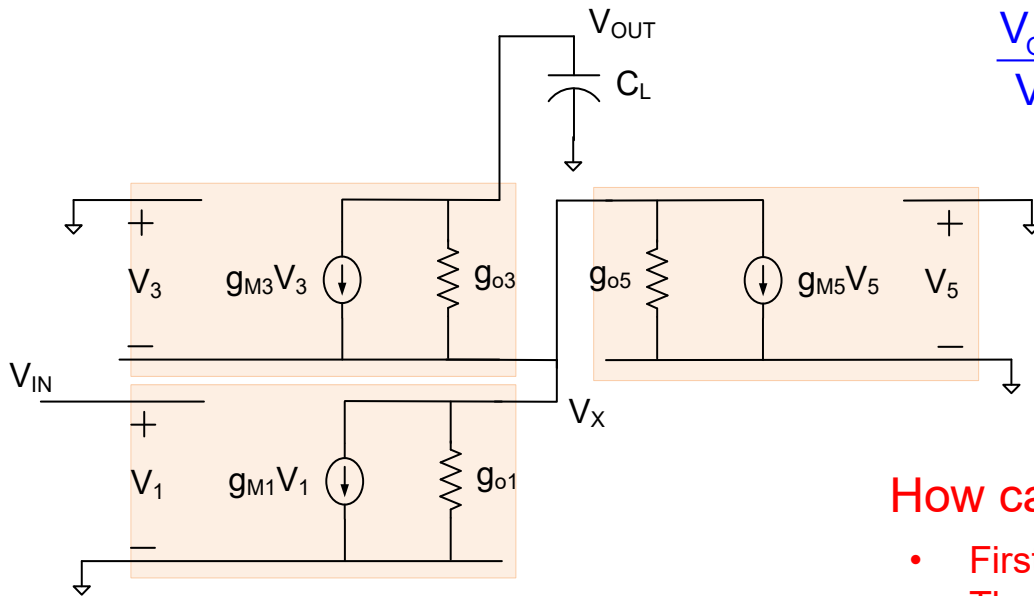

How can this be seen by inspection?

- First observe if all g_o 's are 0, $G_M = g_{m1}$
- Then observe M_3 "cascode" the impedance $g_{o1} + g_{o5}$

Biased Folded Cascode Quarter Circuit

$$\frac{V_{OUT}}{V_{IN}} \cong - \frac{g_{m1}}{sC_L + (g_{o1} + g_{o5}) \frac{g_{o3}}{g_{m3}}}$$

$$A_{v0} \cong \frac{g_{m1}}{(g_{o1} + g_{o5})} \frac{g_{m3}}{g_{o3}}$$

$$GB \cong \frac{g_{m1}}{C_L}$$

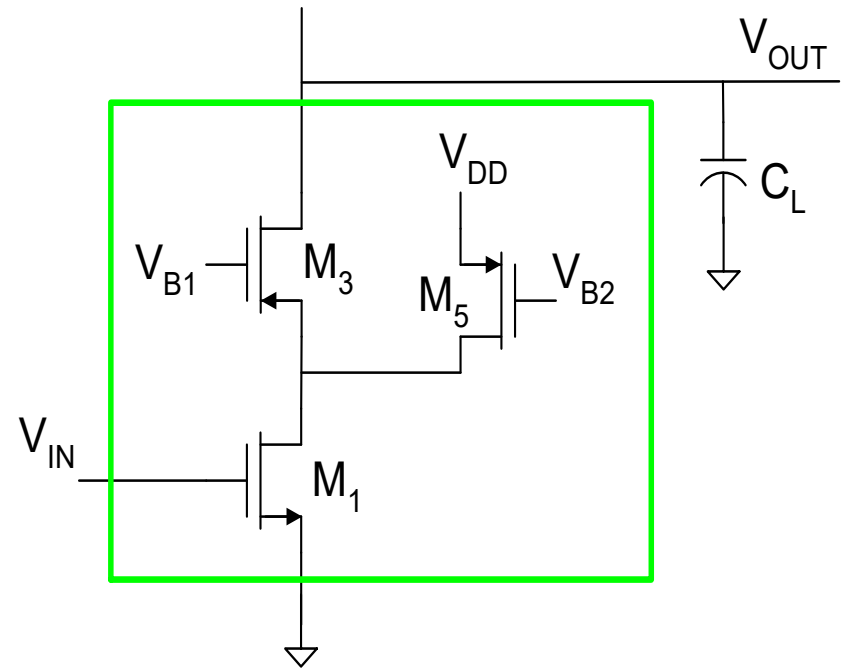

Basic Amplifier Structure Comparisons

(ideal current source biasing)

Small Signal Parameter Domain		
Common Source	$A_{v0} \approx \frac{g_m}{g_o}$	$GB \approx \frac{g_m}{C_L}$
Cascode	$A_{v0} \approx \frac{g_{m1}}{g_{o1}} \frac{g_{m3}}{g_{o3}}$	$GB \approx \frac{g_m}{C_L}$
Regulated Cascode	$A_{v0} \approx \frac{g_{m1}}{g_{o1}} \frac{g_{m3}}{g_{o3}} A$	$GB \approx \frac{g_m}{C_L}$
Folded Cascode	$A_{v0} \approx \frac{g_{m1}}{(g_{o1} + g_{o5})} \frac{g_{m3}}{g_{o3}}$	$GB \approx \frac{g_m}{C_L}$

Basic Amplifier Structure Comparisons

Practical Parameter Domain		
Common Source	$A_{VO} = \left(\frac{2}{\lambda} \right) \left(\frac{1}{V_{EB}} \right)$	$GB = \left(\frac{2P}{V_{DD} C_L} \right) \left(\frac{1}{V_{EB}} \right)$
Cascode	$A_{VO} = \left(\frac{4}{\lambda_1 \lambda_3} \right) \left(\frac{1}{V_{EB1} V_{EB3}} \right)$	$GB = \left(\frac{2P}{V_{DD} C_L} \right) \left(\frac{1}{V_{EB1}} \right)$
Regulated Cascode Θ =pct power in A	$A_{VO} \approx \left(\frac{4}{\lambda_1 \lambda_3} \right) \left(\frac{A}{V_{EB1} V_{EB3}} \right)$	$GB = \left(\frac{2P}{V_{DD} C_L} \right) \left(\frac{(1-\Theta)}{V_{EB1}} \right)$
Folded Cascode Θ =fraction of current of M_5 that is in M_1	$A_{VO} \approx \left(\frac{4\Theta}{(\Theta\lambda_1 + \lambda_5)\lambda_3 V_{EB1} V_{EB3}} \right)$	$GB = \left(\frac{2P}{V_{DD} C_L} \right) \left[\frac{\Theta}{V_{EB1}} \right]$

Biased Folded-Cascode Amplifier

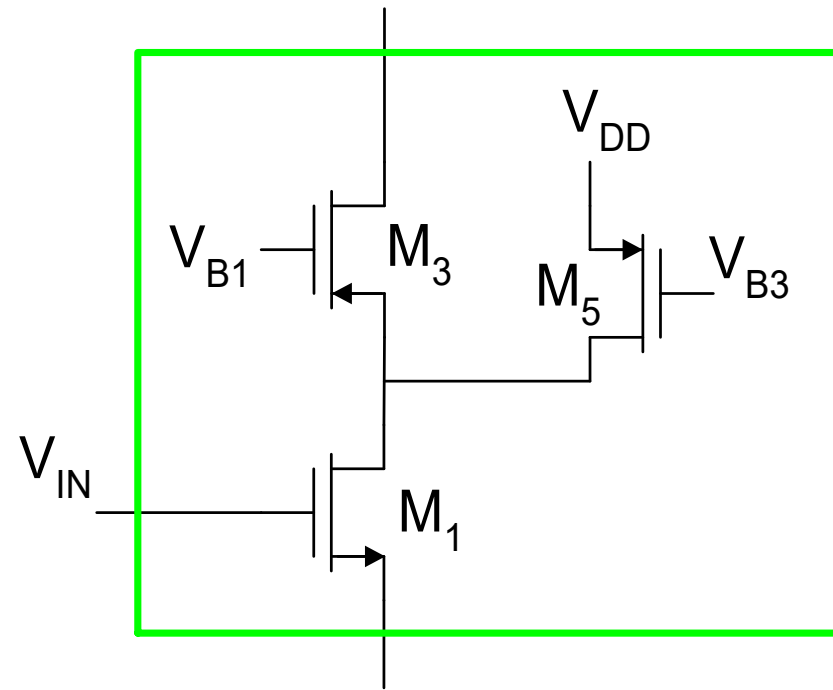

Quarter Circuit

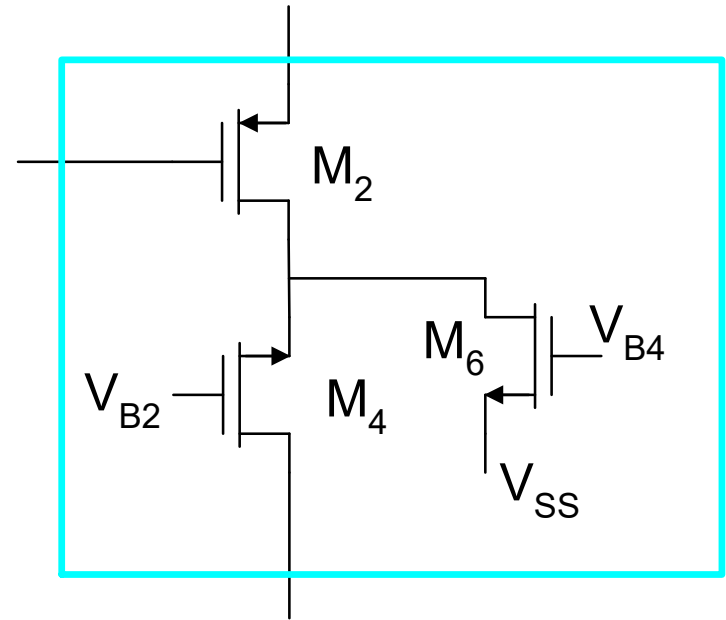

Counterpart Circuit

Folded-Cascode Operational Amplifier

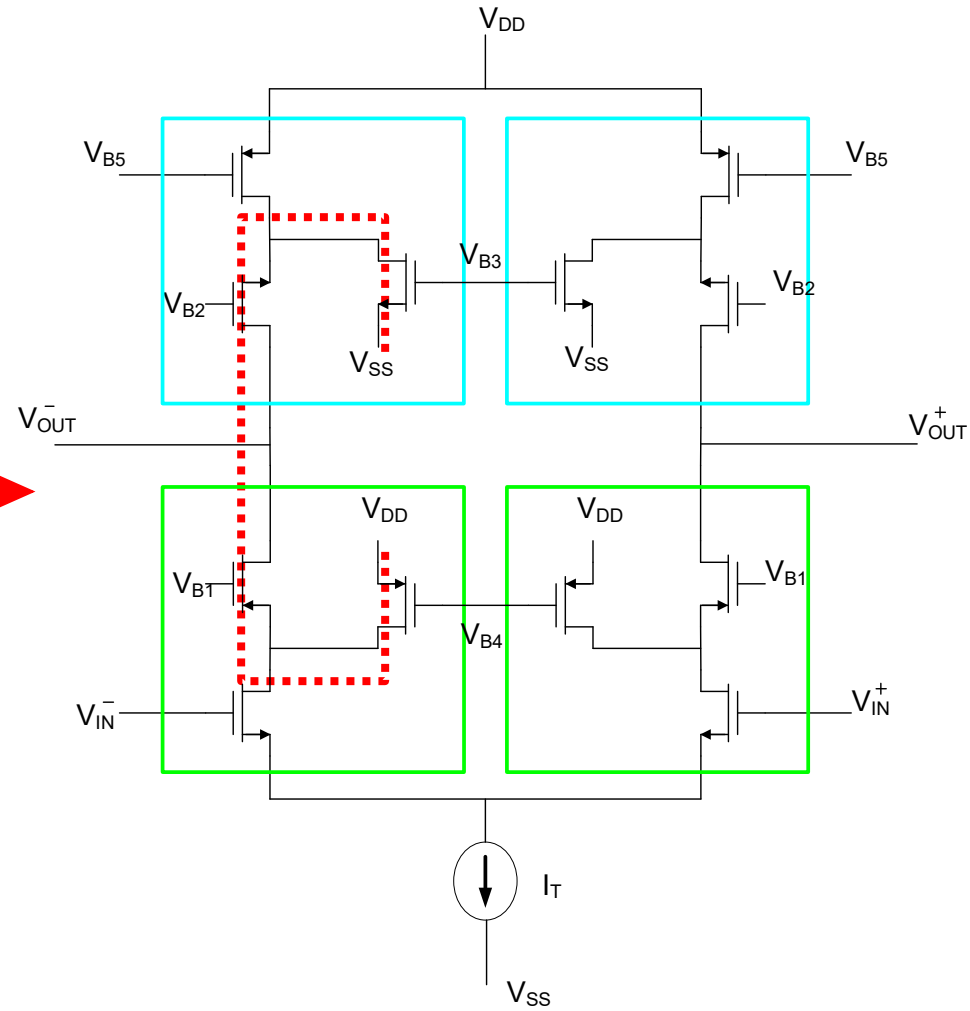
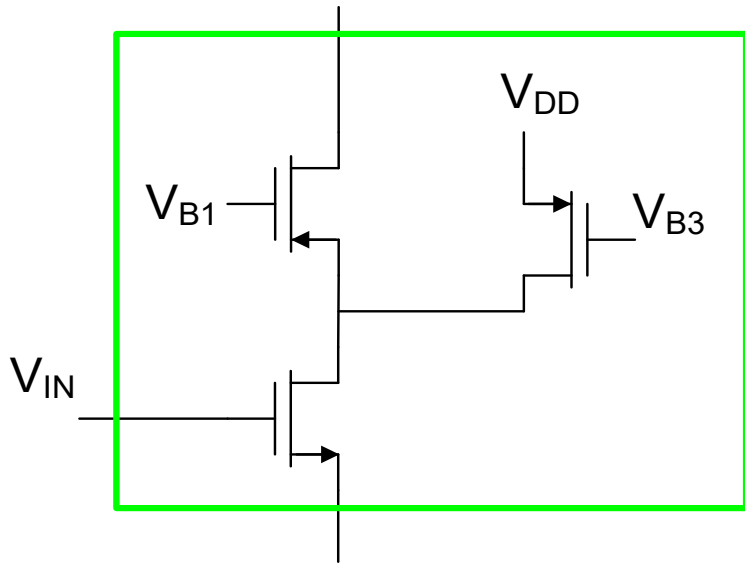

QUARTER CIRCUIT

Op Amp

Folded-Cascode Operational Amplifier (redrawn)

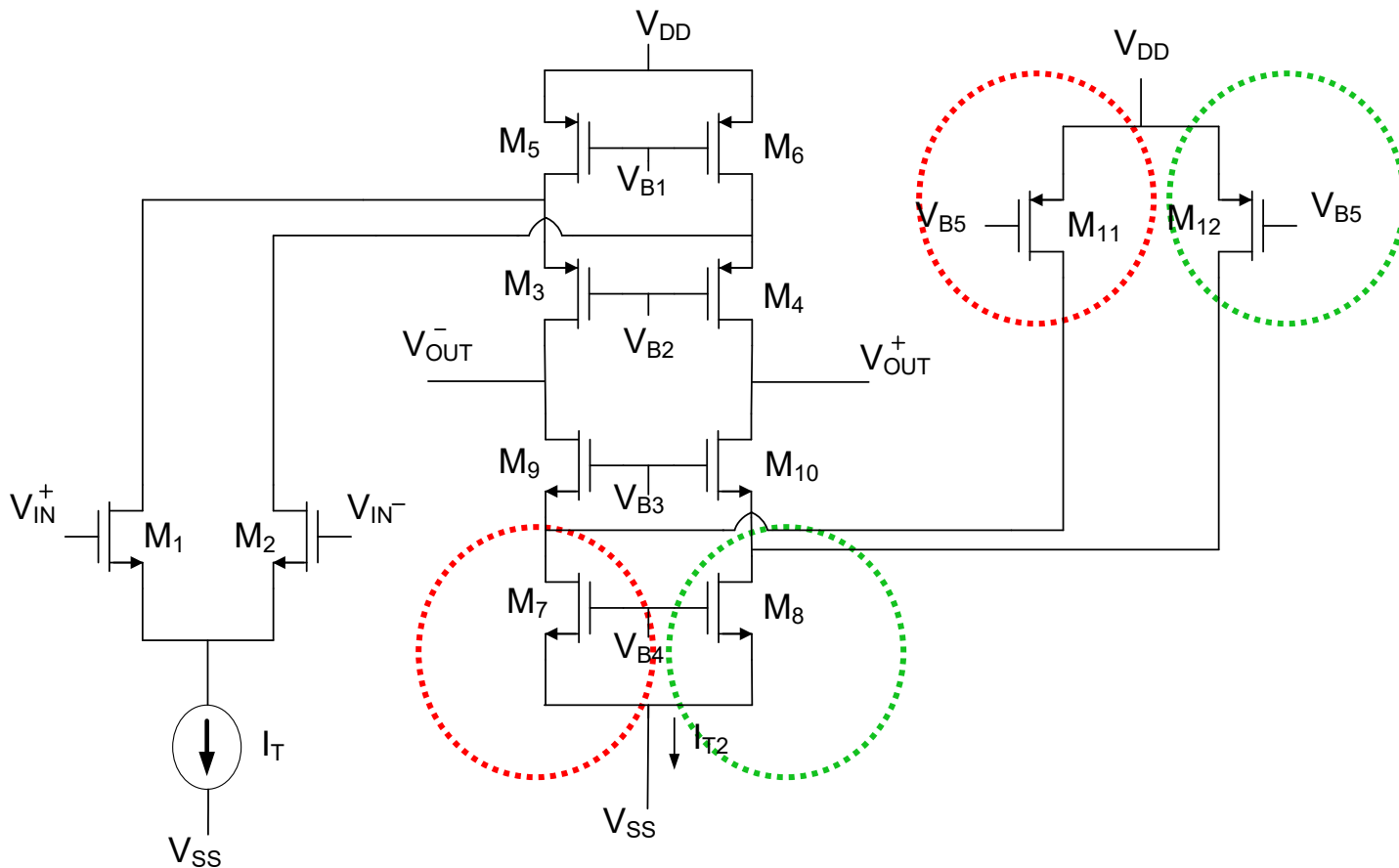

These transistors pair-wise form a current source and one in each pair can be removed

Folded Cascode Op Amp (Single-ended Output)

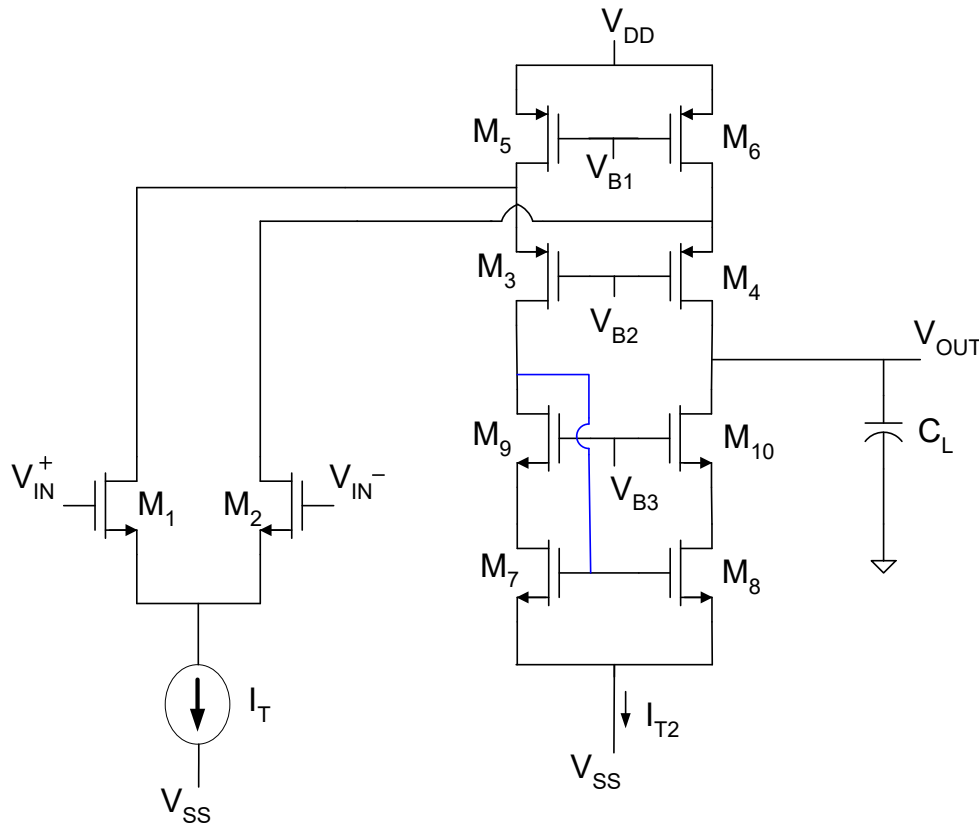

$$A_V(s) \approx - \frac{g_{mEQ}}{sC_L + g_{OEQ}}$$

$$A_{V0} \approx \frac{g_{mEQ}}{g_{OEQ}}$$

$$GB \approx \frac{g_{mEQ}}{C_L}$$

$$g_{mEQ} = g_{m1}$$

$$g_{OEQ} \approx (g_{O1} + g_{O5}) \frac{g_{O3}}{g_{m3}} + (g_{O7}) \frac{g_{O9}}{g_{m9}}$$

$$A_{V0} \approx \frac{g_{m1}}{(g_{O1} + g_{O5}) \frac{g_{O3}}{g_{m3}} + (g_{O7}) \frac{g_{O9}}{g_{m9}}}$$

$$GB = \frac{g_{m1}}{C_L}$$

Operational Amplifier Structure Comparison

Small Signal Parameter Domain			
Reference Op Amp	$A_{vo} = \frac{1}{2} \frac{g_{m1}}{g_{o1} + g_{o3}}$	$GB = \frac{g_{m1}}{2C_L}$	$SR = \frac{I_T}{2C_L}$
Telescopic Cascode	$A_o = \frac{\frac{g_{m1}}{2}}{g_{o1} \frac{g_{o3}}{g_{m3}} + g_{o7} \frac{g_{o5}}{g_{m5}}}$	$GB = \frac{g_{m1}}{2C_L}$	$SR = \frac{I_T}{2C_L}$
Regulated Cascode	$A_o \approx \frac{\frac{g_{m1}}{2}}{g_{o1} \frac{g_{o3}}{g_{m3} A_1} + g_{o7} \frac{g_{o9}}{g_{m9} A_3}}$	$GB = \frac{g_{m1}}{2C_L}$	$SR = \frac{I_T}{2C_L}$
Folded Cascode	$A_o = \frac{\frac{g_{m1}}{2}}{(g_{o1} + g_{o5}) \frac{g_{o3}}{g_{m3}} + g_{o7} \frac{g_{o9}}{g_{m9}}}$	$GB = \frac{g_{m1}}{2C_L}$	$SR = \frac{I_T}{2C_L}$

Operational Amplifier Structure Comparison

Practical Parameter Domain			
Reference Op Amp	$A_{V0} = \left[\frac{1}{\lambda_1 + \lambda_3} \right] \left(\frac{1}{V_{EB1}} \right)$	$GB = \left(\frac{P}{2V_{DD} C_L} \right) \cdot \left[\frac{1}{V_{EB1}} \right]$	$SR = \frac{P}{2V_{DD} C_L}$
Telescopic Cascode	$A_{V0} = \frac{2}{V_{EB1}(\lambda_1 \lambda_3 V_{EB3} + \lambda_5 \lambda_7 V_{EB5})}$	$GB = \left(\frac{P}{2V_{DD} C_L} \right) \cdot \left[\frac{1}{V_{EB1}} \right]$	$SR = \frac{P}{2V_{DD} C_L}$
Regulated Cascode Θ =pct power in A	$A_{V0} \approx \frac{2}{V_{EB1} \left(\frac{\lambda_1 \lambda_3 V_{EB3}}{A_1} + \frac{\lambda_5 \lambda_7 V_{EB7}}{A_3} \right)}$	$GB = \left(\frac{P(1-\Theta)}{2V_{DD} C_L} \right) \cdot \left[\frac{1}{V_{EB1}} \right]$	$SR = \frac{P(1-\Theta)}{2V_{DD} C_L}$
Folded Cascode Θ =fraction of current of M_5 that is in M_1	$A_{V0} = \frac{2\Theta}{V_{EB1}((\Theta\lambda_1 + \lambda_5)\lambda_3 V_{EB3} + (1-\Theta)\lambda_9 \lambda_7 V_{EB9})}$	$GB = \left(\frac{P}{2V_{DD} C_L} \right) \cdot \left[\frac{\Theta}{V_{EB1}} \right]$	$SR = \frac{\Theta P}{2V_{DD} C_L}$

Folded Cascode Op Amp (Single-ended Output)

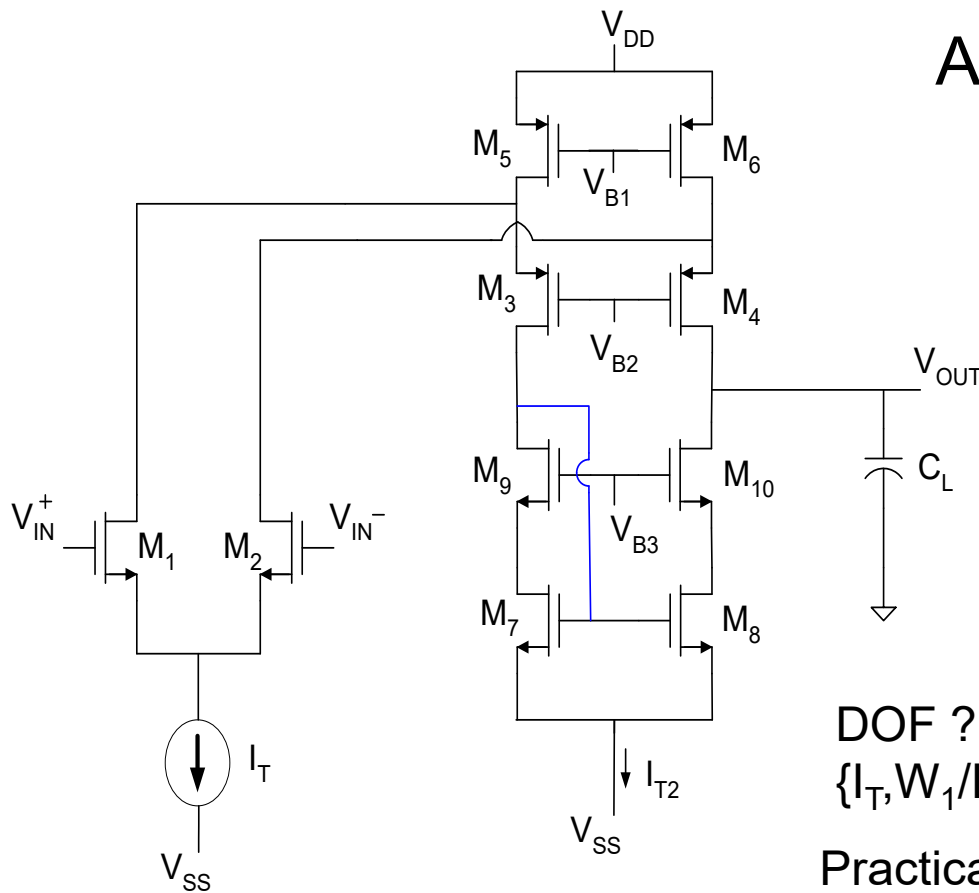

$$A_{v0} \approx \frac{g_{m1}}{(g_{o1} + g_{o5}) \frac{g_{o3}}{g_{m3}} + (g_{o7}) \frac{g_{o9}}{g_{m9}}}$$

$$GB = \frac{g_{m1}}{C_L}$$

How many degrees of freedom are there?

What is a practical design parameter set?

DOF ? **9 DOF**

$\{I_T, W_1/L_1, W_5/L_5, W_3/L_3, W_9/L_9, W_7/L_7, V_{B1}, V_{B2}, V_{B3}\}$

Practical Design Parameters

$\{P, \theta, V_{EB1}, V_{EB3}, V_{EB5}, V_{EB7}, V_{EB9}, V_{B2}, V_{B3}\}$
where $\theta = I_T / (I_T + I_{T2})$

What circuit is this?

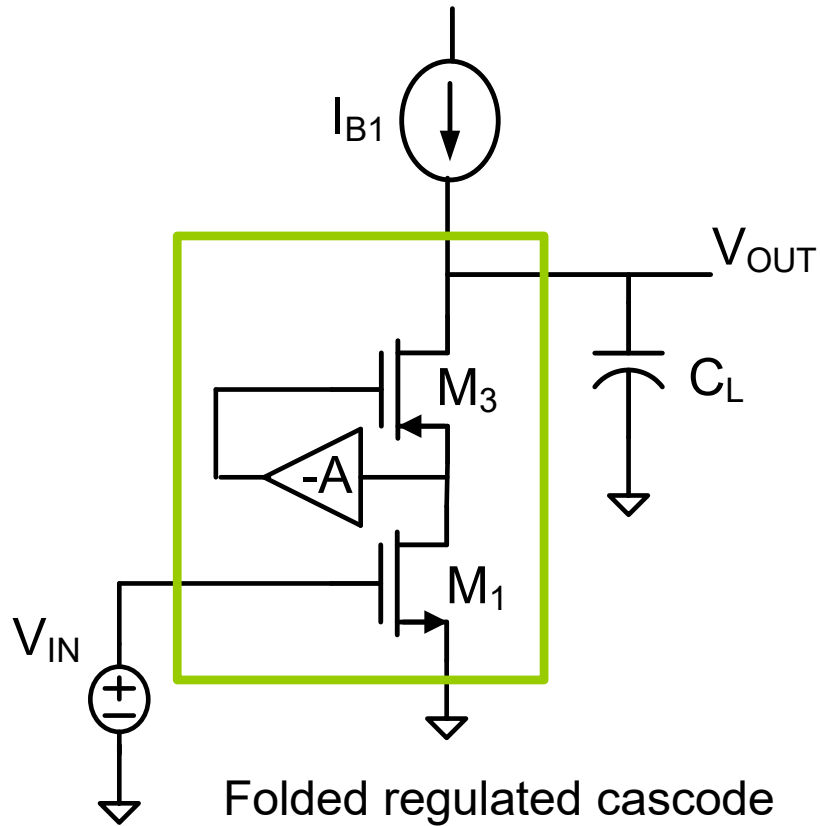

Can it be used to build a useful op amp?

Textbook reference:

Some of the material we have been discussing appears in Chapter 3, some in Chapter 5, and some in Chapter 6 of the Martin and Johns text

In particular, the telescopic and folded cascode structures are referred to as advanced op amps and appear in later chapters of the text



Stay Safe and Stay Healthy !

End of Lecture 8